



DL 011



DL 011

# LEXUS

SINUOSITÀ CHIARE IN UN CONTESTO DI TRASPARENZE, COMBINAZIONI IDEALI E COMPLETE VISSUTE NELL'INCONTRO CON GLI ALTRI.

LIGHT SINUOSITY IN A CONTEXT OF TRAN-SPARENCIES, IDEAL AND COMPLETE COMBINATIONS, LIVING THE ENCOUNTER WITH THE OTHERS.

## Lexus

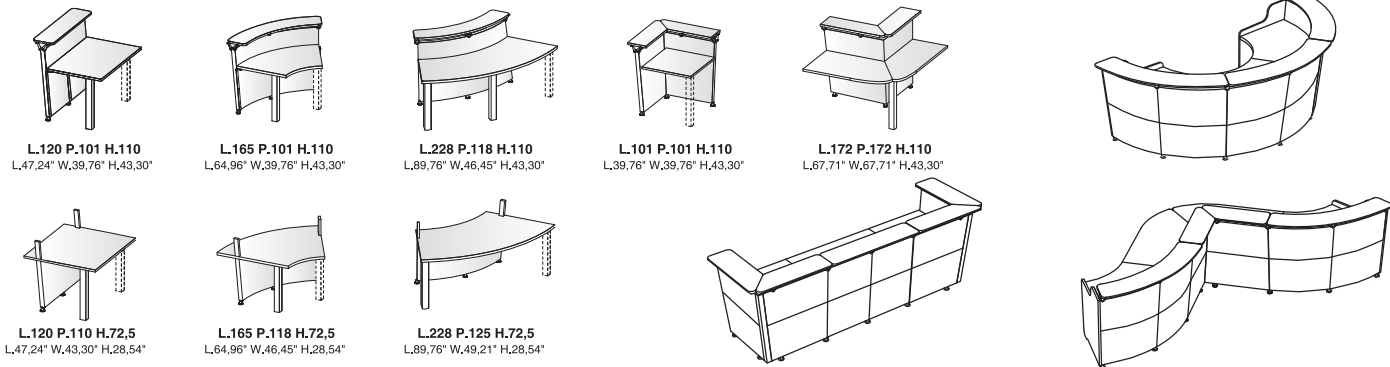

- L.120 P.101 H.110  
L.47.24" W.39.76" H.43.30"
- L.165 P.101 H.110  
L.64.96" W.39.76" H.43.30"
- L.228 P.118 H.110  
L.89.76" W.46.45" H.43.30"
- L.101 P.101 H.110  
L.39.76" W.39.76" H.43.30"
- L.172 P.172 H.110  
L.67.71" W.67.71" H.43.30"
- L.120 P.110 H.72.5  
L.47.24" W.43.30" H.28.54"
- L.165 P.118 H.72.5  
L.64.96" W.46.45" H.28.54"
- L.228 P.125 H.72.5  
L.89.76" W.49.21" H.28.54"

## Edison

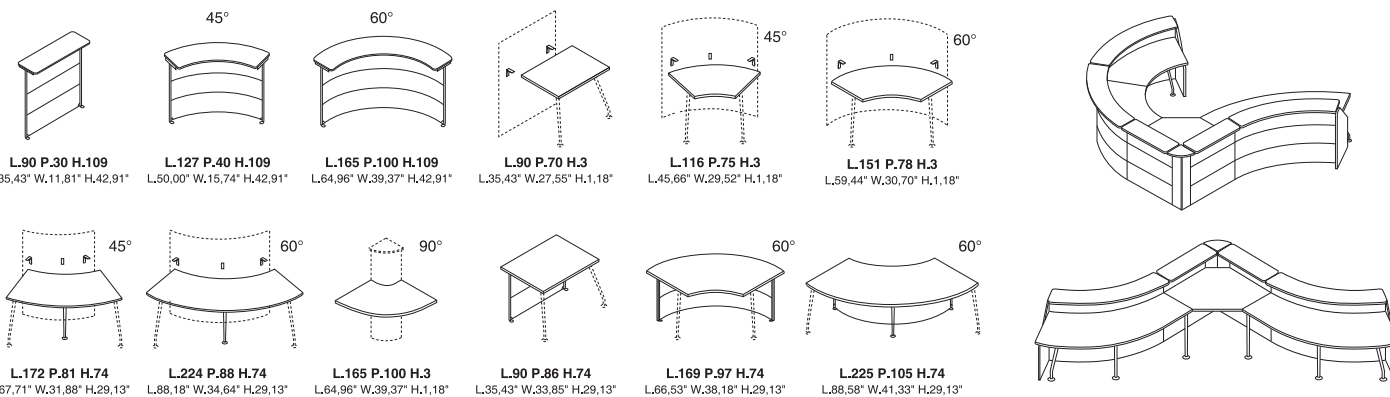

- L.90 P.30 H.109  
L.35.43" W.11.81" H.42.91"
- L.127 P.40 H.109  
L.50.00" W.15.74" H.42.91"
- L.165 P.100 H.109  
L.64.96" W.39.37" H.42.91"
- L.90 P.70 H.3  
L.35.43" W.27.55" H.1.18"
- L.116 P.75 H.3  
L.45.66" W.29.52" H.1.18"
- L.151 P.78 H.3  
L.59.44" W.30.70" H.1.18"
- L.172 P.81 H.74  
L.67.71" W.31.88" H.29.13"
- L.224 P.88 H.74  
L.88.18" W.34.64" H.29.13"
- L.165 P.100 H.3  
L.64.96" W.39.37" H.1.18"
- L.90 P.86 H.74  
L.35.43" W.33.85" H.29.13"
- L.169 P.97 H.74  
L.66.53" W.38.18" H.29.13"
- L.225 P.105 H.74  
L.88.58" W.41.33" H.29.13"

## Kompas

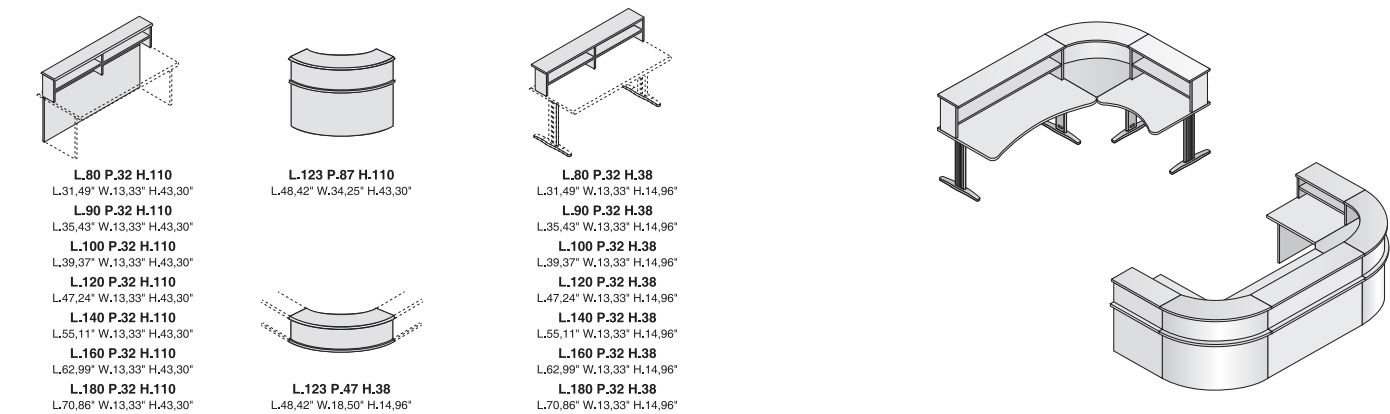

- L.80 P.32 H.110  
L.31.49" W.13.33" H.43.30"
- L.90 P.32 H.110  
L.35.43" W.13.33" H.43.30"
- L.100 P.32 H.110  
L.39.37" W.13.33" H.43.30"
- L.120 P.32 H.110  
L.47.24" W.13.33" H.43.30"
- L.140 P.32 H.110  
L.55.11" W.13.33" H.43.30"
- L.160 P.32 H.110  
L.62.99" W.13.33" H.43.30"
- L.180 P.32 H.110  
L.70.86" W.13.33" H.43.30"
- L.123 P.87 H.110  
L.48.42" W.34.25" H.43.30"
- L.80 P.32 H.38  
L.31.49" W.13.33" H.14.96"
- L.90 P.32 H.38  
L.35.43" W.13.33" H.14.96"
- L.100 P.32 H.38  
L.39.37" W.13.33" H.14.96"
- L.120 P.32 H.38  
L.47.24" W.13.33" H.14.96"
- L.140 P.32 H.38  
L.55.11" W.13.33" H.14.96"
- L.160 P.32 H.38  
L.62.99" W.13.33" H.14.96"
- L.180 P.32 H.38  
L.70.86" W.13.33" H.14.96"

33 Multimedia Studio

# RECEPTION

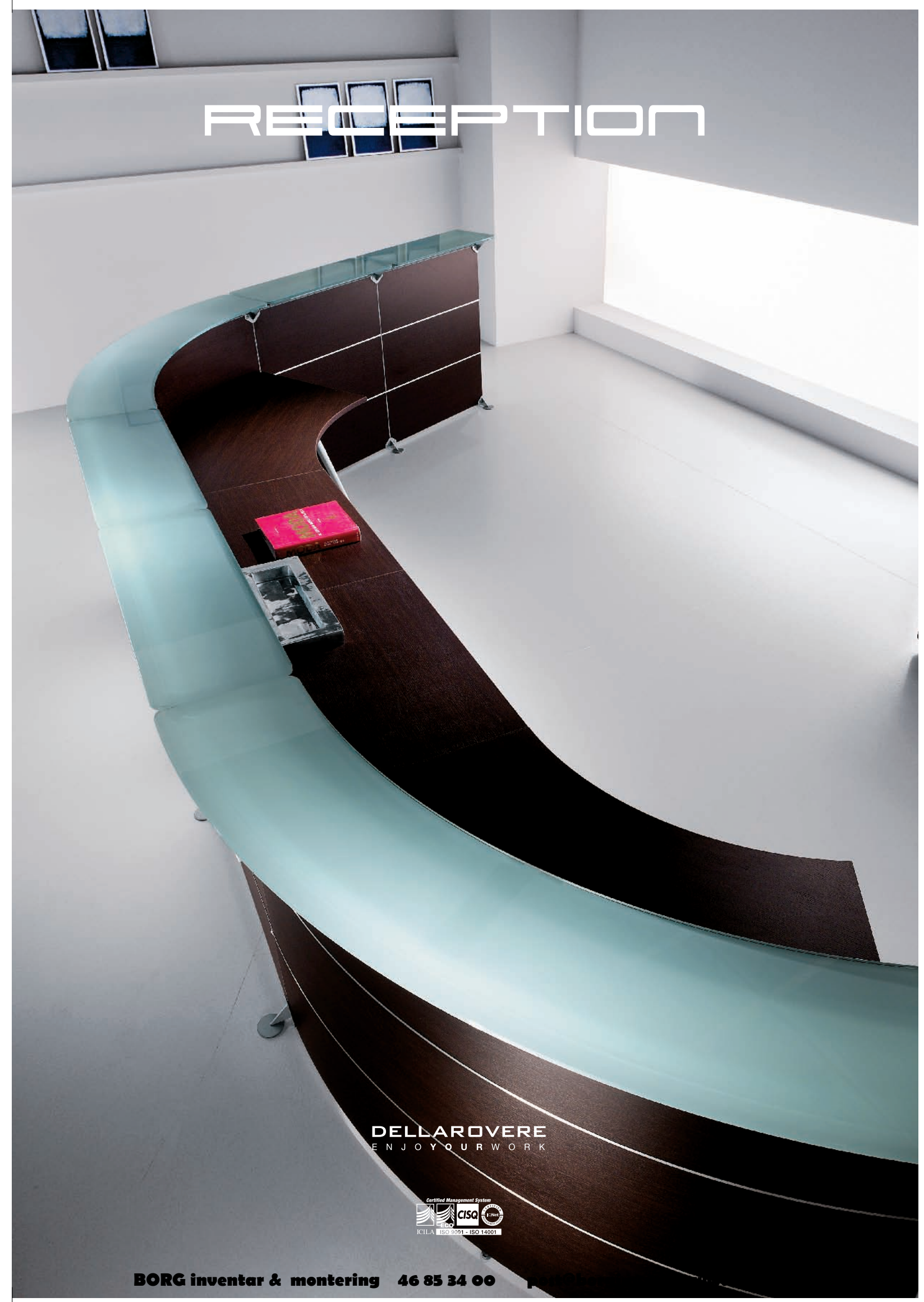

DO08402 SETTEMBRE/SEMPTEMBER 2008

DELLAROVERE  
ENJOY YOUR WORK

DELLAROVERE ENJOY YOUR WORK  
Tel. +39 0721 20400, Fax +39 0721 200033  
dellarovere@dellarovere.it www.dellarovere.it



# KOMPAS

IL RIGORE COMPOSITIVO DELLE GEOMETRIE, UTILIZZA MATERIALI D'AVANGUARDIA. IL COLORE GIOCA UN RUOLO IMPORTANTE NEL DETERMINARE IL CARATTERE DELLE COMPOSIZIONI. FORMA, CONFORT ED ELEGANZA COME FRUTTO DELL'ATTENZIONE POSTA NELLE SCELTE.

THE COMPOSITIONAL SIMPLICITY OF THE GEOMETRY, THE USE OF AVANT-GARDE MATERIALS, THE USE OF COLOUR IN DETERMINING THE CHARACTER OF THE COMPOSITIONS. FORM, COMFORT AND ELEGANCE: THE RESULT OF CAREFULLY MADE CHOICES.



DK 023

# EDISON



DE 027

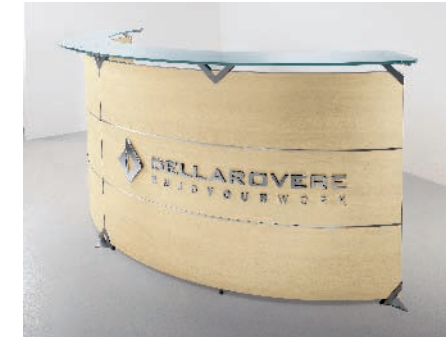

ED 02



ED 01



ED 03



DEFINIRE GLI SPAZI DI UN UFFICIO DI PRESTIGIO. TO DEFINE SPACES OF A PRESTIGIOUS OFFICE.



La razionalità si esprime al meglio. Una postazione comoda che consente di muoversi in piena libertà.

Rationality at the maximum level. A comfortable work-station for people that need to feel free.

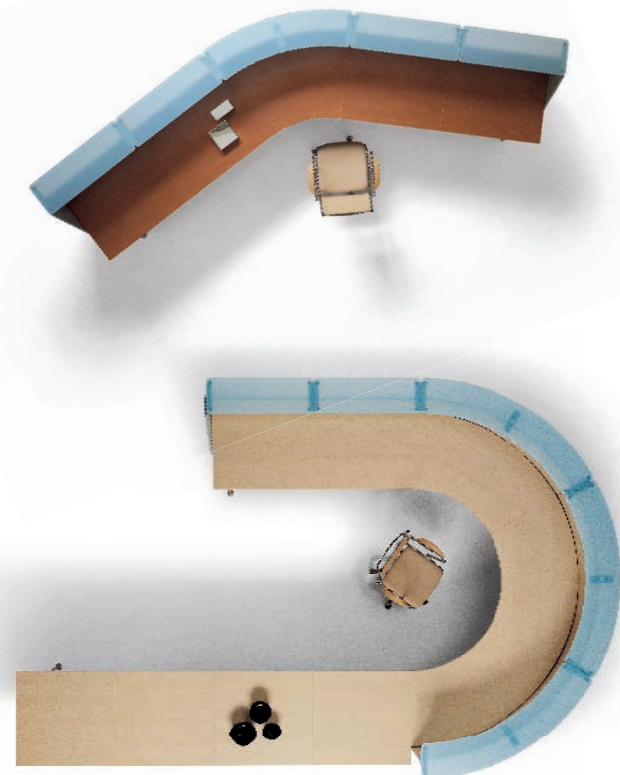

DE 025



DE 022 DE 021

ANCORA UN'ESEMPIO DI ATTENZIONE NEGLI ACCOSTAMENTI E NELLE SCELTE DI NATURA TECNICA ED ESTETICA, CI RIPROPONGONO UN CONCETTO DI SOLIDA BELLEZZA.

LESS THICK, SOPHISTICATED TECHNICAL MATERIALS. THE LINES OF THE NEW LEG REFLECTS THE TASTE FOR PURITY OF SHAPE. PRESTIGIOUS WITH THE CHROME PLATE FINISH, ELEGANT IN THE SATIN FINISHED VERSION.



DE 020